

KEMPER Regulating Valves

- ▶ The complete solution for correct balancing of domestic hot water return installations

**KEMPER**

Two tasks of hot water systems

Legionella control and comfortable supply of hot water

The control of Legionella requires temperatures throughout the hot water system that avoids Legionella growth.

The temperature of a centralized hot water tank should not be below 60 °C. In the time of no hot water consumption, the hot water may cool down to environmental temperature without a hot water circulating system. This would support the growth of Legionella and extend the delay time of hot water when a tap is turned on. The requirements of limitation of delay times may even not be met.

In large systems, a hot water circulation system is commonly used to overcome the above mentioned obstacles and to maintain the temperature within the entire hot water system to not fall below 55 °C (Germany) or 50 °C (UK). The design of a hot water return system has to comply with national standards and must take different aspects into consideration. The function has to be designed in dependence of the heat loss of the pipework, the required circulation flow rate and the pressure drop of the furthest circuit. The design of a proper hot water circulation system also requires a minimum of dead legs to avoid stagnation.

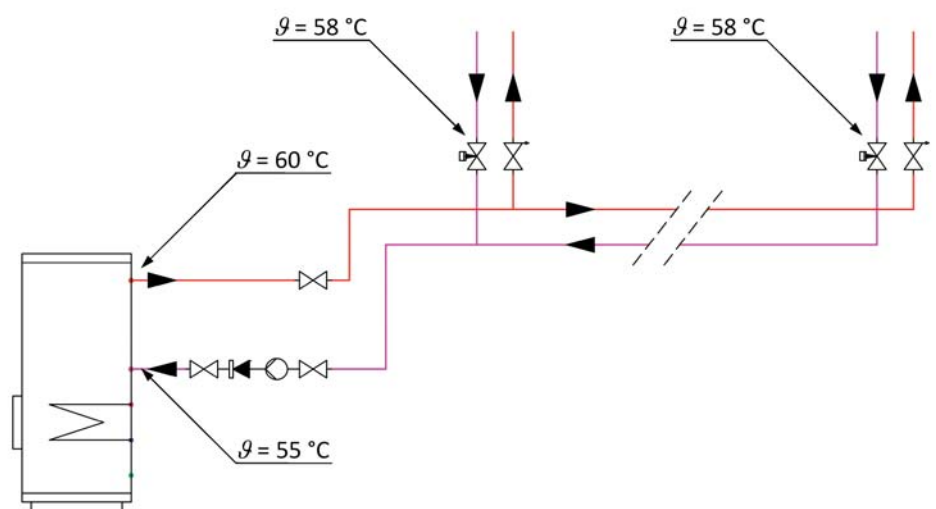

Principle of a hydraulically balanced hot water return system.

Hot water return systems

The necessity of hydraulic balancing

The heat that gets lost via the surface of the hot water pipework has to be compensated by the heat energy transported by the hot water return flow rate. This balance must be achieved at any point of the pipework. As the hot water return pump is sized to overcome the pressure drop of the furthest circuit, the hot water return flow in all other circuits has to be balanced by regulating valves. If this is not done, the bulk of the hot water return flow rate is only circulating in the circuits near to the pump and the temperature in the further circuits drops below the critical temperature of 50 °C. Such situations increase the energy cost and can lead to shortened life span of installation materials.

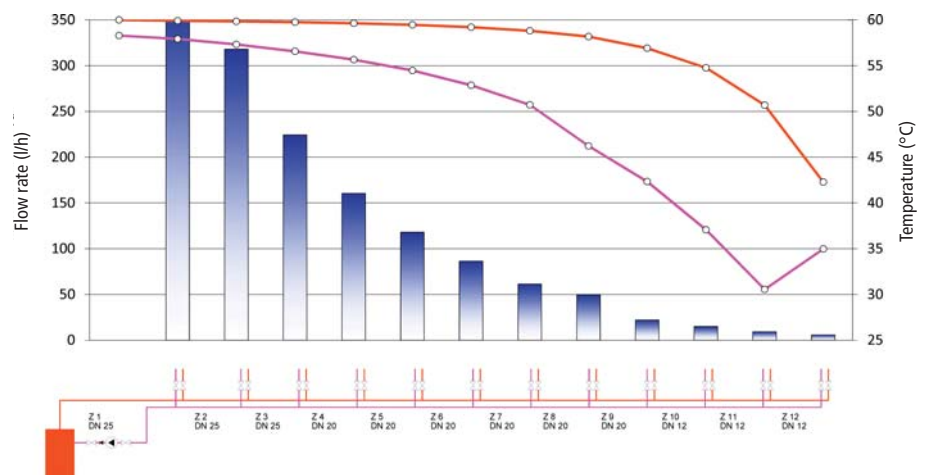

Distribution of the hot water return flow rate in a system with 12 unbalanced risers.

The aim of a hydraulic balancing calculation is to equalize the pressure drop in every circuit at required flow rate and a limitation of velocity. The difference between pressure loss of a circuit and available pump head has to be added by the regulating valve. Therefore KEMPER provides „static“ double-regulating valves and „automatic“ double-regulating valves. A hot water system with KEMPER regulating valves maintains proper hot water temperatures within the whole system.

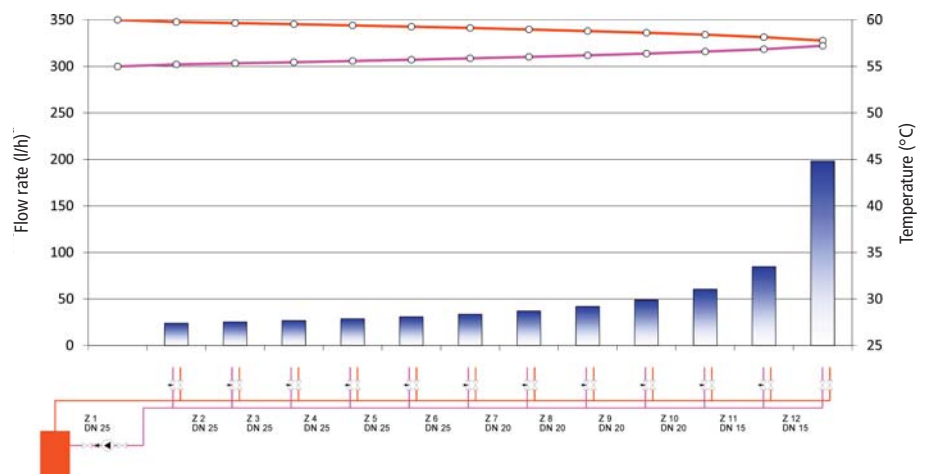

Distribution of the hot water return flow rate in a system with 12 balanced risers.

Hydraulic balancing

Hot water return only in the riser

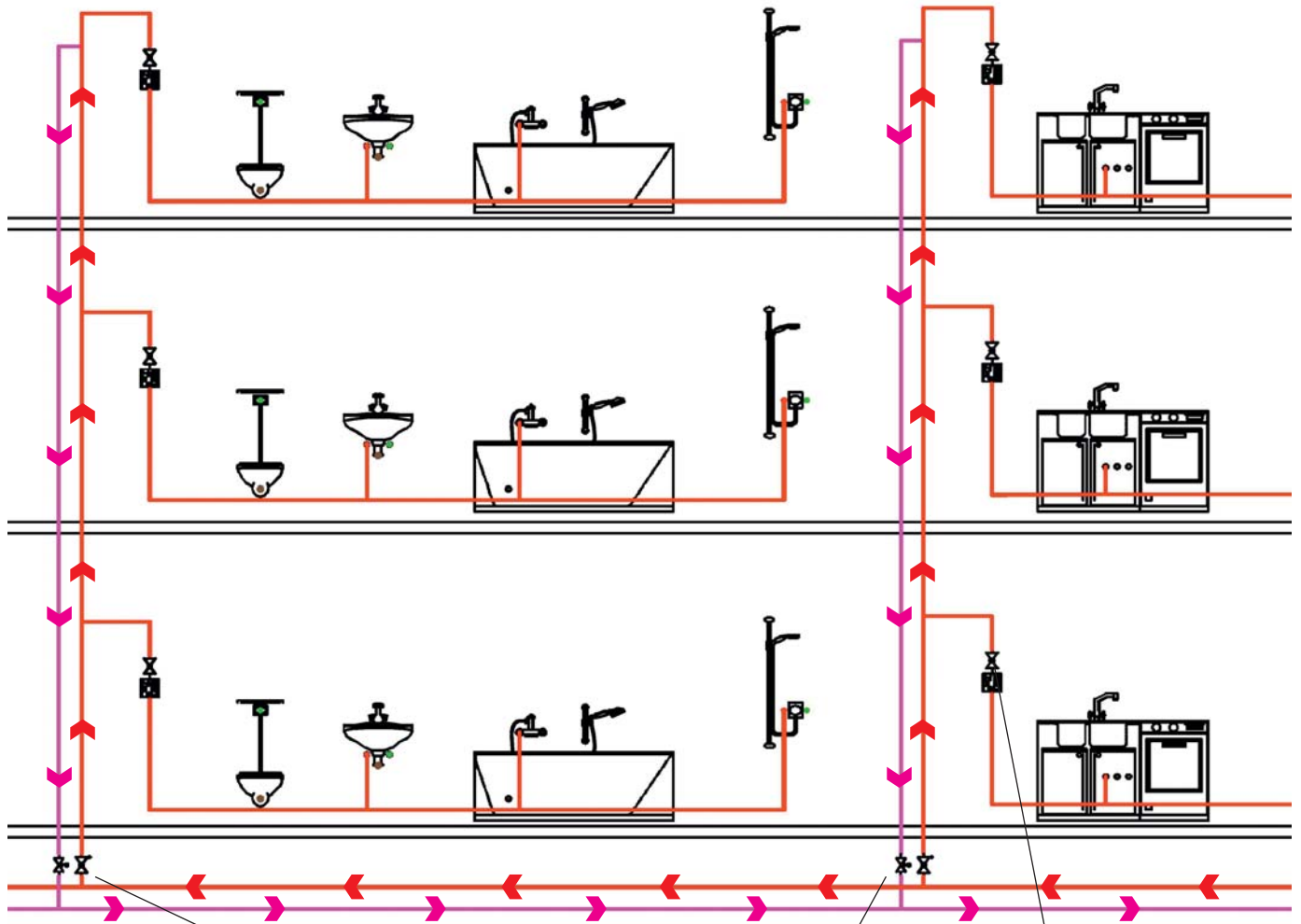

Principle of a hot water system with hot water return connection in the riser due to water metering in the apartment.

- 1** = automatic double-regulating valve for larger circuits (page 6)
- 2** = automatic double-regulating valve for small circuits (page 8)
- 3** = static double-regulating valve (page 10)



1 MULTI-THERM
Figure 141 OG



KEMPER quarter turn stop valve
for concealed installation
Figure 585 00

Hydraulic balancing

Hot water return connected to last outlet

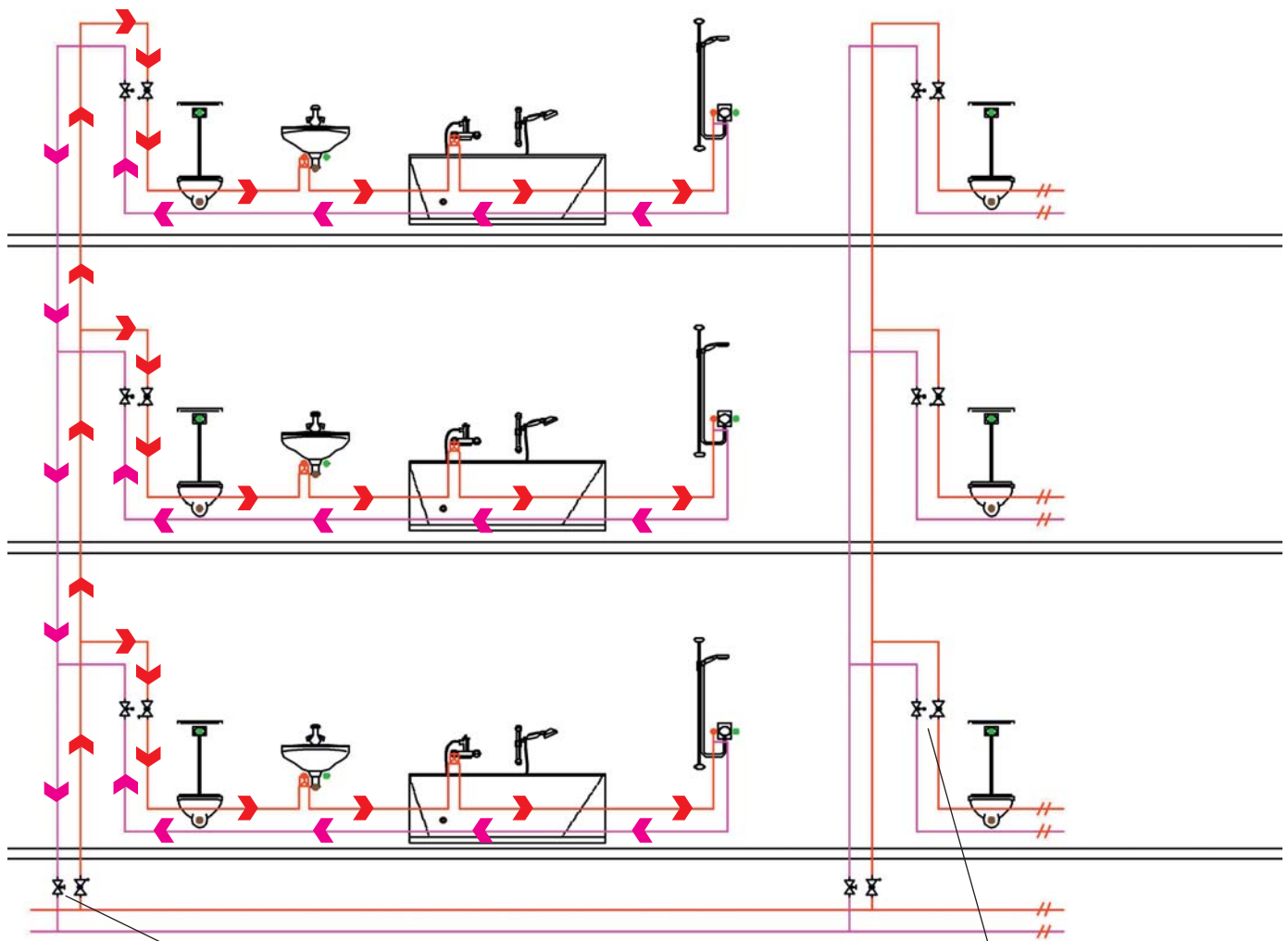

Principle of a hot water system with hot water return connection at the furthest outlet in each floor.

Note:

In most installations, it is required to have two or more „levels“ of balancing, as the piping branches several times. Every branch has to be balanced. Therefore it is important that only one automatic regulating valve is used in a circuit. The rest must be static regulating valves.



3 MULTI-FIX-PLUS
Figure 150 6G



2 ETA-THERM
Figure 130 or Figure 540

1

KEMPER MULTI-THERM Automatic Double-Regulating Valve

The all-rounder for hydraulic balancing of risers

The use of KEMPER MULTI-THERM Automatic Double-Regulating Valves reduces the effort of manual presetting of static balancing valves. The MULTI-THERM enables easy installation and commissioning and proper balancing of hot water return flow rates in classic riser-installations.

The KEMPER MULTI-THERM combines several functions in one valve!

Beneath hydraulic balancing within its operating range of 50-65 °C, it can combine the following functions:

- automatic support of thermal disinfection
- indication of water temperature
- shut-off function for maintenance on the system
- plugged connection for a drain or sampling valve



Figure 141 0G
(temperature indicator and drain are optional extras)



Benefits at a glance

- shut-off function and temperature indicator in one part
- automatic adjustment for thermal disinfection
- made of gunmetal resistant to aggressive water - or stainless steel
- free of dead spots
- DVGW, WRAS, ÖVGW, SVGW, KIWA, WSD certificates
- optional Pt 1000 available for connection to BMS

Balancing

The required temperature can be adjusted between 50 and 65 °C directly at the top of the valve. KEMPER MULTI-THERM valves are used for automatic balancing of the hot water return temperature in risers.

Isolating and measuring

The valve insert for isolating the pipe is capped. By turning the cap, the valve is opened or closed. The cap can be removed to insert a Pt 1000 (picture 1) or a dial-thermometer (picture 2). Therefore it is possible to read temperature information via BMS or the KEMPER CONTROL-PLUS measuring device (Figure 138 00 002).

Thermal disinfection

In normal operation, the thermal valve opens if the preset temperature is not reached and reduces the flow when the preset temperature is exceeded. But it never closes completely. A remaining flow must be granted. To make thermal disinfection possible, the valve reopens if the temperature rises above 62 °C.

The MULTI-THERM valve fulfills all technical requirements for hot water return systems. If the valve is preset to a temperature of e. g. 58 °C, the valve will be in maximum open position till the temperature reaches 52 °C. Above 52 °C, the MULTI-THERM starts to throttle the flow and reaches the maximum throttle position when the preset temperature is reached. When the hot water heater is turned to 70 °C to do a thermal disinfection, the valve starts to open at 62 °C and reaches a thermal disinfection position at 70 °C.

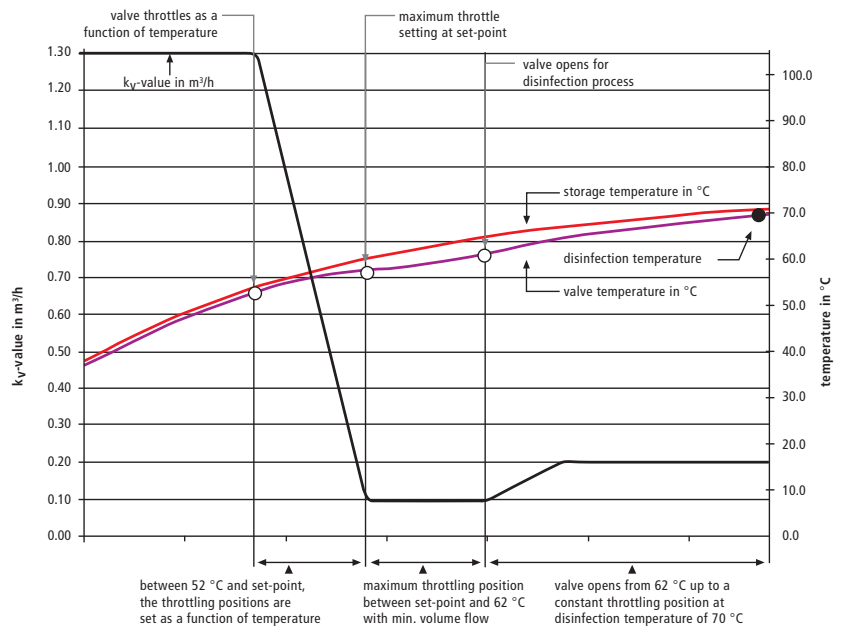

Control characteristic

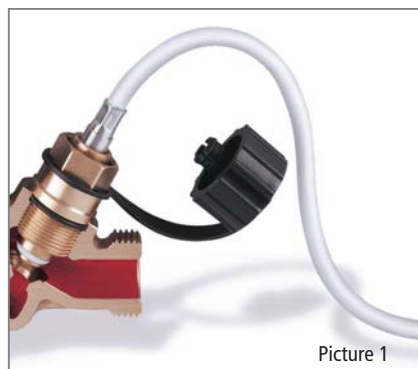

Picture 1



Picture 2

Figure	Article description
141 0G	MULTI-THERM, gunmetal, male union thread, DN 15 - 25
143 00	MULTI-THERM, gunmetal, female thread, DN 15 - 25
143 22	MULTI-THERM, gunmetal, MAPRESS press fit, DN 15 - 20
143 40	MULTI-THERM, gunmetal, MEPLA press fit, DN 15 - 20
041 0G	NIRO MULTI-THERM, stainless steel, male union thread, DN 15 - 25

2

KEMPER ETA-THERM Automatic Double-Regulating Valve The sensible valve for hydraulic balancing of short circuits in rooms

If hygienic and/or comfort requirements are very high, the hot water return pipe can be connected to the last supplied outlet in a bathroom. Hot water comes out of the tap instantaneous when it is opened. Hydraulic balancing of the return lines from rooms can be done with the KEMPER ETA-THERM Automatic Double-Regulating Valve.

As the pipework of hot water and hot water return is normally quite short, there is not so much heat loss and the required hot water return flow rate is small. The ETA-THERM has been developed for this case and the k_v -range fits to this situation ($k_{v\min} = 0,05$, $k_{v\max} = 0,4$).

The KEMPER ETA-THERM also includes a function to isolate the pipe and eliminates the need to install a separate stop valve on the hot water return pipe.

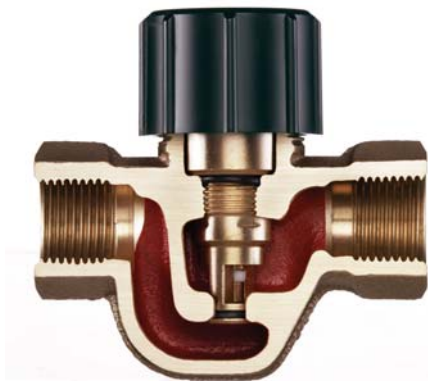

Figure 130 0G



Benefits at a glance

- shut-off function and hydraulic balancing in one part
- change of presetting indicated with notches
- self cleaning to avoid collection of fine debris
- made of gunmetal resistant to aggressive water - or stainless steel
- free of dead spots

Accessible installation

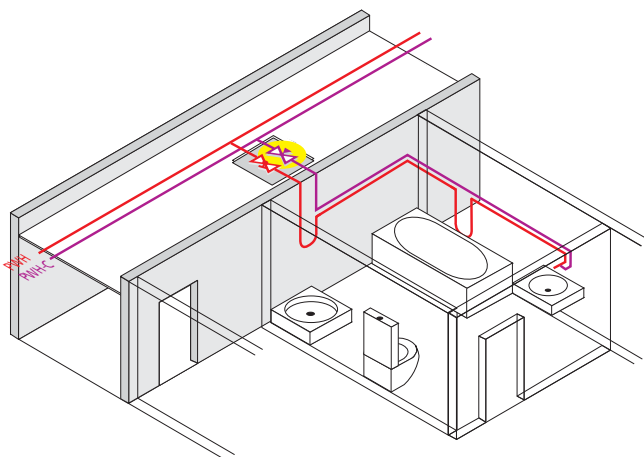

Concealed installation

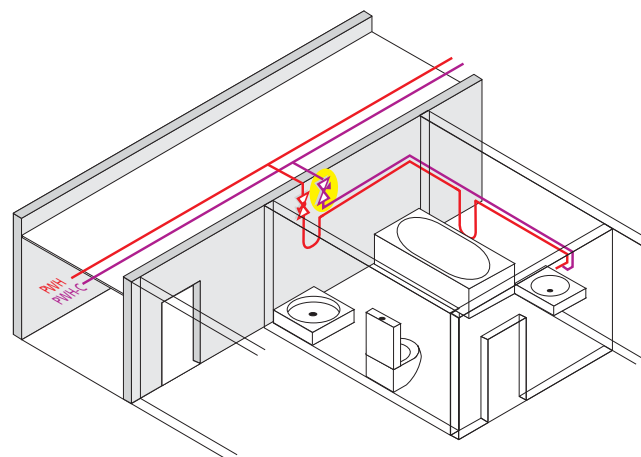

male union thread, Figure 130 0G



female pipe thread, Figure 131 00



female pipe thread, Figure 540 02



MAPRESS press fit connection, Figure 542 02

Figure	Article description
130 0G	ETA-THERM, operating range 56 °C - 58 °C, male union thread, DN 15
131 00	ETA-THERM, operating range 56 °C - 58 °C, female pipe thread, DN 15
134 0G	ETA-THERM, operating range 62 °C - 64 °C, male union thread, DN 15
136 00	ETA-THERM, operating range 62 °C - 64 °C, female pipe thread, DN 15

Figure	Article description
544 02	UP-ETA-THERM, operating range 56 °C - 58 °C, concealed installation, SANPRESS/PROFIPRESS press fit, DN 15
540 02	UP-ETA-THERM, operating range 56 °C - 58 °C, concealed installation, female pipe thread, DN 15
542 02	UP-ETA-THERM, operating range 56 °C - 58 °C, concealed installation, MAPRESS press fit, DN 15
540 62	UP-ETA-THERM, operating range 62 °C - 64 °C, concealed installation, female thread, DN 15

3

KEMPER MULTI-FIX-PLUS Static Double-Regulating Valve The preliminary balancing of hot water return branches

Only the first valve (in direction of flow) in a hot water return system can be a thermal regulating valve like the MULTI-THERM or ETA-THERM. All other balancing valves have to be a static double-regulating valve. They are used for a preliminary balancing of different hot water return branches in e. g. corridors, risers or wards. The fine balancing is done with thermal regulating valves that adopt to the appearing operating point in the system.

The calculated presetting of the static valves and the use of thermal balancing valves makes commissioning very easy. No time wasting commissioning anymore - calculate, preset, operate!

KEMPER MULTI-FIX Static Double-Regulating Valves also include an isolating function. The presetting is not changed when the valve is closed or opened.



Figure 150 6G



Figure 151 06



The KEMPER CONTROL-PLUS flow- and temperature sensor and measuring device are clever tools to evaluate and log flow rates and temperatures of a hot water return pipe. It helps to analyze and improve the hot water system to reduce energy loss and cost.

KEMPER CONTROL-PLUS Sensor:
Figure 138 4G (frequency signal)

KEMPER CONTROL-PLUS Hand-Held Measuring Device:
Figure 138 00 002

Benefits at a glance

- stop valve and regulating valve in one valve
- made of gunmetal resistant to aggressive water
- free of dead spots
- presetting is retained after isolating and reopening of the valve
- including dial thermometer
- optional Pt 1000, sampling valve and drain valve available

The presetting of static regulating valves like the MULTI-FIX-PLUS has to be calculated with regards to the required hot water return flow rate at a defined pressure drop. The required presetting can be taken from the flow charts.

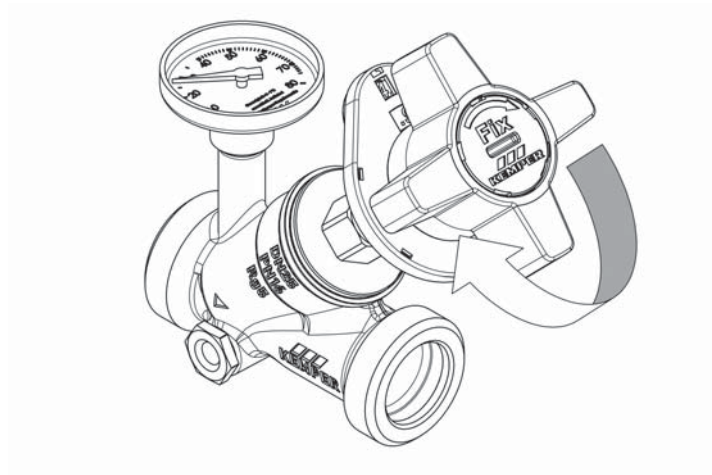

MULTI-FIX-PLUS (example)

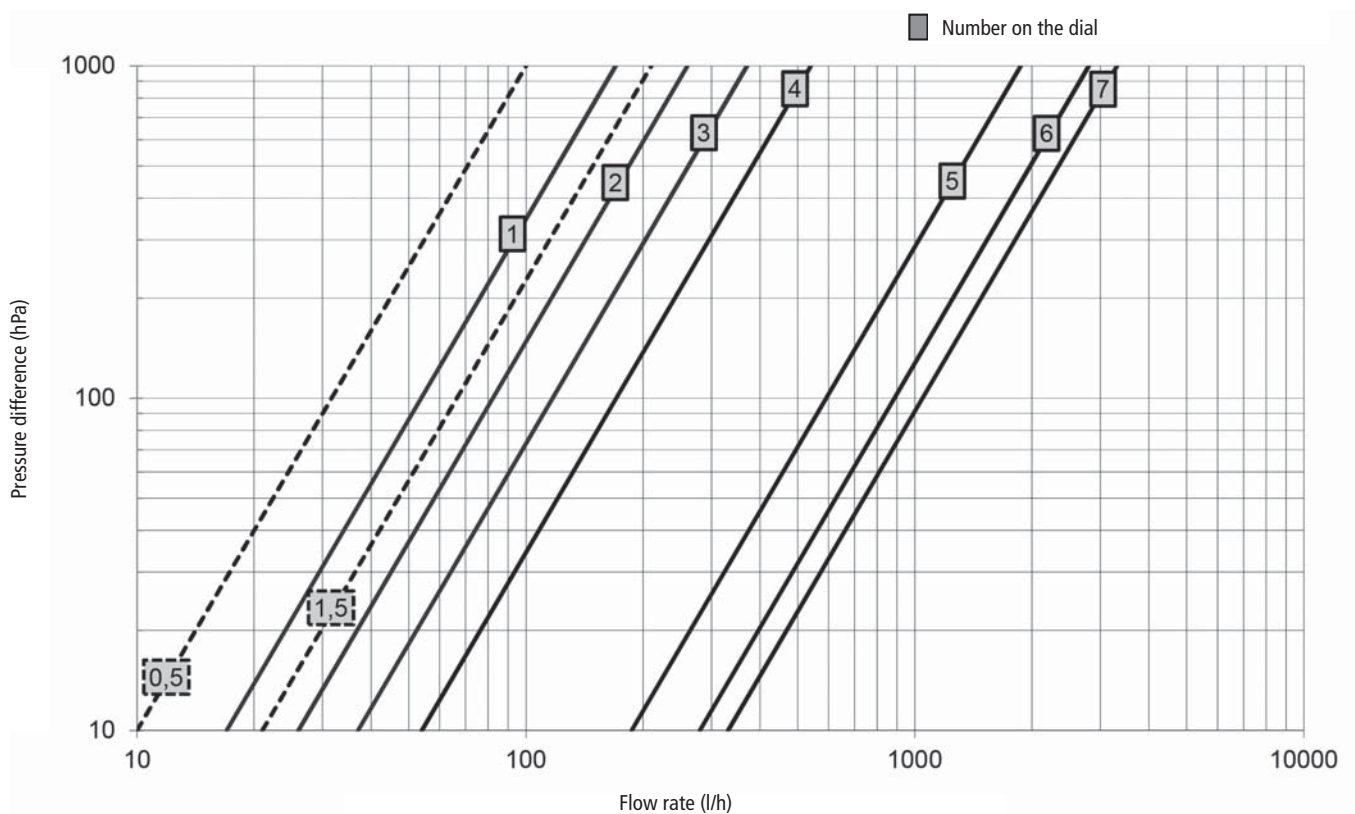

Figure	Article description
150 6G	MULTI-FIX-PLUS, with dial thermometer and plugged port, male union thread, DN 15 - 50
151 06	MULTI-FIX-PLUS, with dial thermometer and plugged port, female pipe thread, DN 15 - 50



Kemper UK & Ireland Ltd.
2 Ripple Court
Brockridge business park
Twynning
Tewkesbury
Glos, GL20 6FG
Phone +44 16 84 - 85 49 30
Fax +44 16 84 - 85 49 31
www.kemper-uk.com
info@kemper-uk.com

Gebr. Kemper GmbH + Co. KG
Metallwerke
Harkortstraße 5
57462 Olpe

Phone +49 2761 891-0
Fax +49 2761 891-175

info@kemper-olpe.de
www.kemper-olpe.de